

The Atlas Copco logo is positioned in the top right corner of the image. It consists of the company name "Atlas Copco" in a white, italicized serif font, centered between two horizontal white bars. The background of the logo is a solid teal color.

Atlas Copco

A large, semi-transparent teal graphic overlay is located in the bottom left corner. It features a technical drawing of a circular mechanical component, possibly a compressor or engine part, with various lines, circles, and dimension lines. The drawing is rendered in a light blue/white color against the teal background.

Compressed air solutions for mobility industries

Railway | Bus | Heavy-duty vehicles

Keeping you ...

Since 1873, Atlas Copco is the world leader in high-quality compressed air equipment for the mobility industry.

Applications worldwide

Atlas Copco compressors are used in railway and road-bound vehicles throughout the world. From standard to custom-design, for every specification and application, we meet all of your compressed air requirements with top quality, highly reliable equipment and service across the globe.

Mobility solutions center

Experience and expertise cannot be outsourced. That is why we develop our own, often patented, compressed air technologies specifically for the mobility industry. In our IRIS-certified Mobility Solutions Center near Paris, specialists oversee every aspect of designing, building and marketing of Atlas Copco's mobility compressors and equipment.

Aftermarket services

The purchase is just the start. Atlas Copco offers a wide range of services to keep your compressed air system performing optimally.

- Commissioning and start-up
- Field follow-up
- Maintenance parts and kits
- Maintenance jobs on site
- Overhaul parts and kits
- Overhauls
- Modifications
- Monitoring

on track since 1873

1873

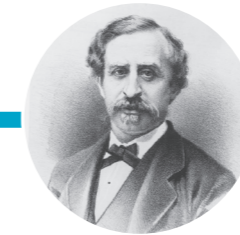

AB Atlas was founded.

1900s



Production of steam locomotives, pneumatic equipment and compressors.

1950s



Arpic Engineering Belgium was acquired to start Atlas Copco's journey to global leadership in mobility solutions.

1976

First Atlas Copco Railway Competence Center screw compressors installed in Swiss locomotives.

1996



Atlas Copco's Railway Competence Center established in Chambly.

2016



Atlas Copco's Railway Competence Center receives ISO 9001 IRIS Certification.

2019

Atlas Copco's Railway Competence Center became Mobility Solutions Center for mobility Industries.

Nowadays



Sustainability and new technologies for better air treatments.



Low weight
reduces operating costs



Small footprint
maximizes space for passengers
and cargo



Low sound
ensures a comfortable travel
environment



High reliability
creates peace of mind



Low lifecycle costs
eliminate post-purchase expenses
for low cost of ownership

**Atlas Copco meets all these needs,
and more!**

A powerful product for every mobility needs

Reliability you can trust

Using an absolute minimum of moving parts – all relevant ones corrosion resistant – our mobility air systems are built to last. They are designed to withstand external vibrations, shock loads and extreme ambient conditions. Atlas Copco mobility air compressors are designed and produced in accordance with all relevant international mobility norms and standards, then fully tested and qualified one-by-one.

The cost-efficiency you need

Mobility operations are facing strong pressure from the public and government to increase operational performance and punctuality, while reducing costs. Atlas Copco helps achieve these goals. Our patented, efficient compressors reduce energy consumption to a minimum. Coupled with long lasting components, our solutions provide the lowest lifecycle costs, allowing you to keep costs in check.

Full feature: everything integrated

Atlas Copco pioneered the innovative Full Feature compressor concept. By selecting Full Feature, you get an all-in-one, customized compressed air system for your mobility application, including mounting brackets, quick connectors, integrated dryers, filters and instant condensate treatment. The whole package is compact, simple to maintain, and easy to install on top of, inside or underneath the vehicle. Just plug in and enjoy the clean reliable compressed air: we take care of all the rest.

Your ticket to top-quality compressors

Available in a number of variants to match your specific needs, Atlas Copco mobility compressors are designed for reliable, continuous duty and minimum maintenance. A full range of auxiliary equipment is also available.

LFpR and LfXR pantograph Compressors

For use on any electrically driven railway vehicle with a pneumatic pantograph, LFpR and LfXR oil-free piston pantograph compressors offer a space-saving design, easy installation and low maintenance. Available from 40 to 83 l/min (1.4 to 3 cfm) free air delivery.



LER/LTR/LFR piston compressors

Exceptionally reliable at a low cost, LER/LTR oil-lubricated and LFR oil-free aluminum piston compressors are built for high performance and extended lifetime, even in the harshest ambient conditions. Available from 140 to 1100 l/min (5 to 39 cfm) free air delivery.

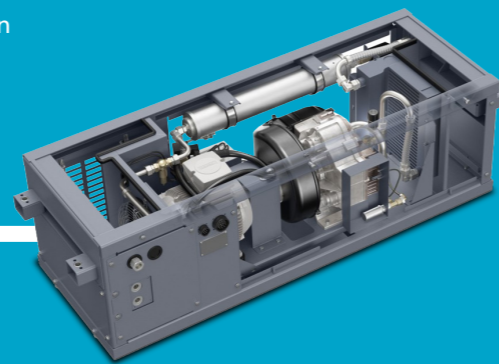

SFR oil-free scroll compressors

The SFR orbiting scroll compressor is an oil-free, low maintenance compressed air solution validated for all mobility applications. Reliable, rated for a 100% duty cycle and suited for the harshest conditions. The SFR offers performance and flexibility with low noise levels, vibrations and life cycle costs. To be installed on top of, inside or underneath the vehicle; special light-weight models for electric and hybrid buses. As one-stage version available from 200 to 475 l/min (7 to 16 cfm) free air delivery.

SFR oil-free 2-stage scroll compressors

The railway-approved oil-free SFR with 2-stage scroll element delivers a patented super flow for high performance and extended lifetime. Its direct drive concept ensures lean dimensions, low weight, short service time and high reliability. Noise levels, vibrations and life cycle costs are reduced to a minimum. As 2-stage version available from 570 to 1550 l/min (22 to 55 cfm) free air delivery.

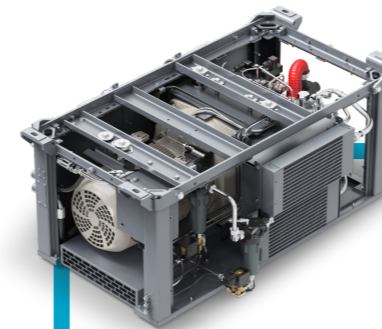

GAR 11-37 oil-injected screw compressors

The space-saving GAR 11-37 oil-injected screw compressors are designed, built and tested to meet the toughest ambient conditions, such as extreme climates, high humidity, heavy dust-load, shocks and vibrations. Available from 1100 to 4500 l/min (40 to 160 cfm) free air delivery.

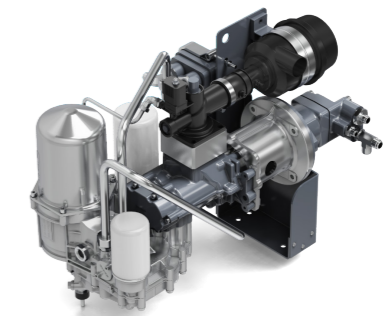

GAR 5-14 oil-injected screw compressors

The oil-injected, air-cooled GAR 5-14 screw compressors are designed for dedicated mobility applications in extreme ambient conditions. They are a reliable, compact, low-weight, low-noise solution meant to be installed on top of, inside or underneath the vehicle. Available from 500 to 1600 l/min (18 to 57 cfm) free air delivery.

GAR 11-37 oil-injected screw compressors

The space-saving GAR 11-37 oil-injected screw compressors are designed, built and tested to meet the toughest ambient conditions, such as extreme climates, high humidity, heavy dust-load, shocks and vibrations. Available from 1100 to 4500 l/min (40 to 160 cfm) free air delivery.

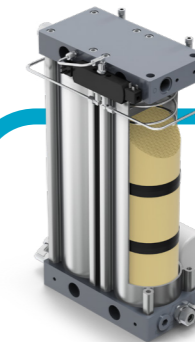

Air filtration and drying solutions

SDR membrane dryers with pre-filter remove oil, particles and moisture from the compressed air, ensuring the lowest pressure drop and purge air loss for the highest efficiency. Available for the whole product range of Atlas Copco's mobility compressors. Designed to operate inside the compressor package but also as stand-alone unit.

Customized products

Every Atlas Copco mobility compressed air system is built to exacting standards, norms and directives. Customized products are designed to meet all different installation conditions and specific requirements in terms of frame, control system or power supply.



A dedicated compressor for every application

Atlas Copco mobility systems supply the high-quality compressed air that keeps railway and road-bound vehicles running safely and smoothly. From light rail vehicles and buses to high-speed trains, heavy haul locomotives and other harsh ambient equipment, our comprehensive range of compressors includes the right product for your application

Railway vehicles

- Locomotives
- High speed trains
- Multiple unit trains
- Commuters
- Light rail vehicles
- Subway vehicles
- Urban trams
- People movers
- Mining locomotives
- Switchers and shunters

Road-bound vehicles

- Mining vehicles
- Electric and hybrid buses
- Mobile service trucks
- Fire fighting trucks
- Agricultural vehicles

Other harsh environment applications

- Outdoor port cranes, open pits, dusty plants
- Outdoor water locks with limited space
- Foundries with hot and dusty conditions

Typical mobility applications

- Brake systems
- Pantograph devices
- Air suspension, high speed curve tilting, station platform leveling
- Kneeling of buses for passenger comfort
- Auxiliary systems: doors, toilets, air conditioning distribution, sanding devices, entry steps and stairs, signal horns, windscreen wipers, greasing devices, etc.

A complete product range

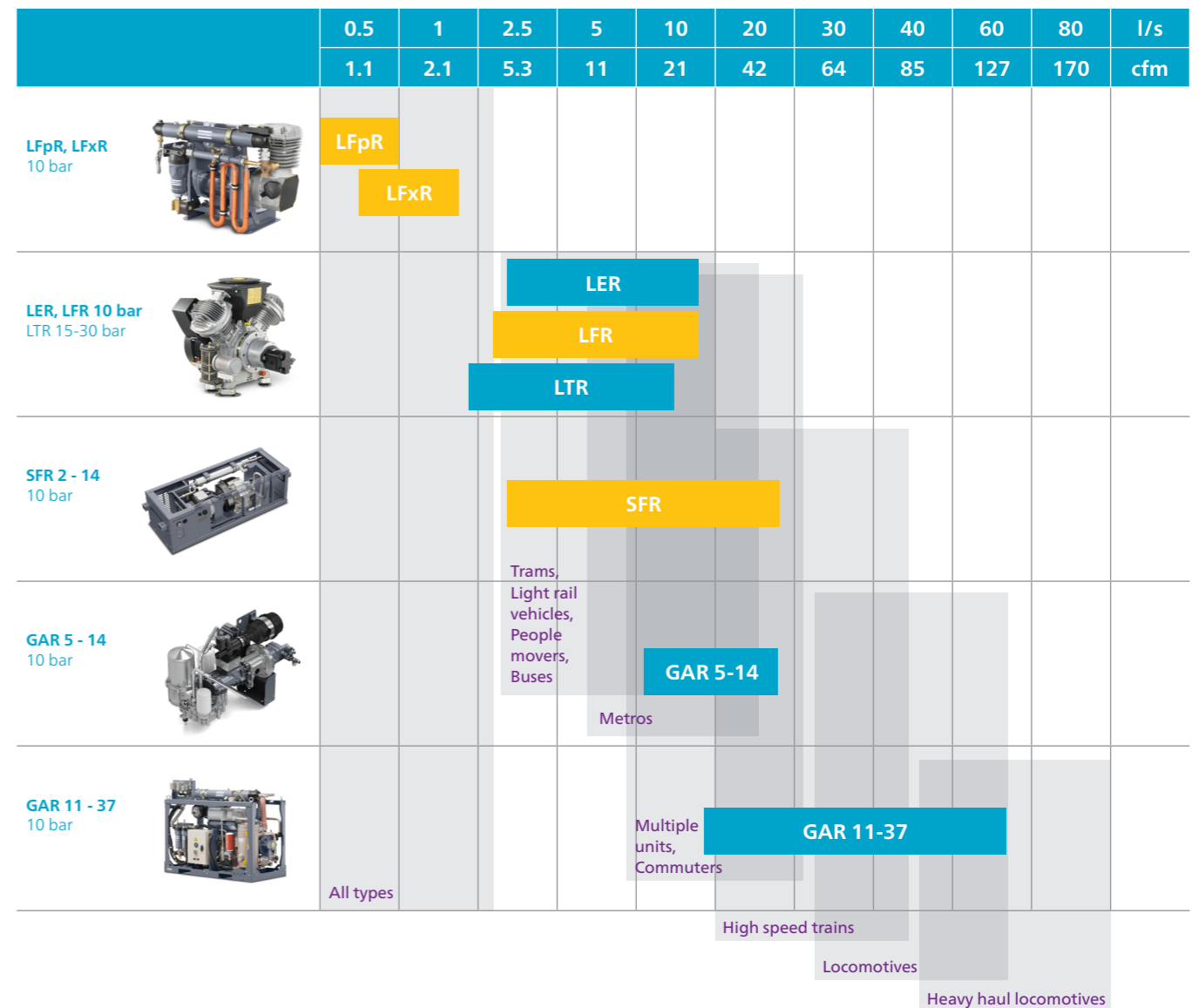

Certified quality

Each Atlas Copco mobility air system is built to exacting standards, norms and directives to perform reliably in harsh vibration and ambient conditions.

The highest industry standards

We work in compliance with the highest quality management and Health & Safety regulations. All Atlas Copco Business Areas have been approved by Lloyd's Register Quality Assurance in compliance with the following Management System Standards:

ISO 9001: 2015	/	Quality Assurance
ISO 14001: 2015	/	Environmental Management
OHSAS 18001: 2007	/	Occupational Health & Safety



IRIS certification

Atlas Copco has received the IRIS International Railway Industry Standard (ISO/TS 22163) certification for its state-of-the-art Mobility Solutions Center in Chambly, France. The certification covers the center's design, development, manufacturing and aftermarket activities. The ISO 9001-based IRIS is the gold standard of the railway industry. Most companies in the sector will only work with suppliers that have earned this railway-specific quality certification.



Always ride first class

Our commitment to you extends beyond supplying top-quality, sustainable compressors and auxiliary products.

With a presence in most countries – and support available 24/7 – we will always be there for you when you need us with expert advice, customer service, skilled technicians and genuine spare parts.



Presence in over 180 countries



Dedicated customer service



Skilled technicians available 24/7



Fast delivery of genuine spare parts



Atlas Copco Mobility Solution Center (MSC)

165 rue Pierre Curie 60230 Chambly FRANCE

Phone: +33 1 393 73 30 00

Reg. no: FR 41 388 163 099

atlascopco.com

